

單向減壓閥 Pressure Reducing and Check Valves

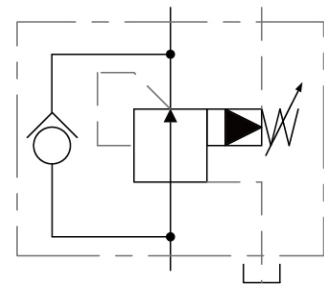

■ 選購指南 HOW TO ORDER

BRCV - 03		G	A	10
系列編號 SERIES NUMBER	閥口徑 VALVE SIZE	安裝型式 TYPE OF CONNECTION	壓力調整範圍 PRESSURE ADJ. RANGE MPa (kgf/cm ²)	設計號 DESIGN NUMBER
BRCV	- 03 : 3/8"	G : 座墊式 Sub-plated Type T : 配管式 Thread Type	- A : 0.3 (3) - 3.5 (35)	- 10 (標準型) Standard Type
	- 06 : 3/4"		- B : 0.7 (7) - 7 (70)	
	- 10 : 1-1/4"		- C : 3.5 (35) - 14 (140) - H : 7 (70) - 21 (210)	

■ 規格說明 SPECIFICATIONS

型式 Model Series	最高使用壓力 Max. Operated Pressure MPa (kgf/cm ²)	最大流量 Max. Flow (L/min)	重量 Weight (kg)	
BRCV-03 (G/T)	21 (210)	50	5.6	4.8
BRCV-06 (G/T)		125	8.6	8
BRCV-10 (G/T)		250	13.8	13.8

■ 安裝螺絲 MOUNTING BOLTS

型式 Model Series	安裝螺絲 Mounting Cap Screw
BRCV-03G	M 10 X 70 L 4pcs
BRCV-06G	M 10 X 80 L 4pcs
BRCV-10G	M 10 X 90 L 6pcs

單向減壓閥 Pressure Reducing and Check Valves

● BRCV-(03/06)G

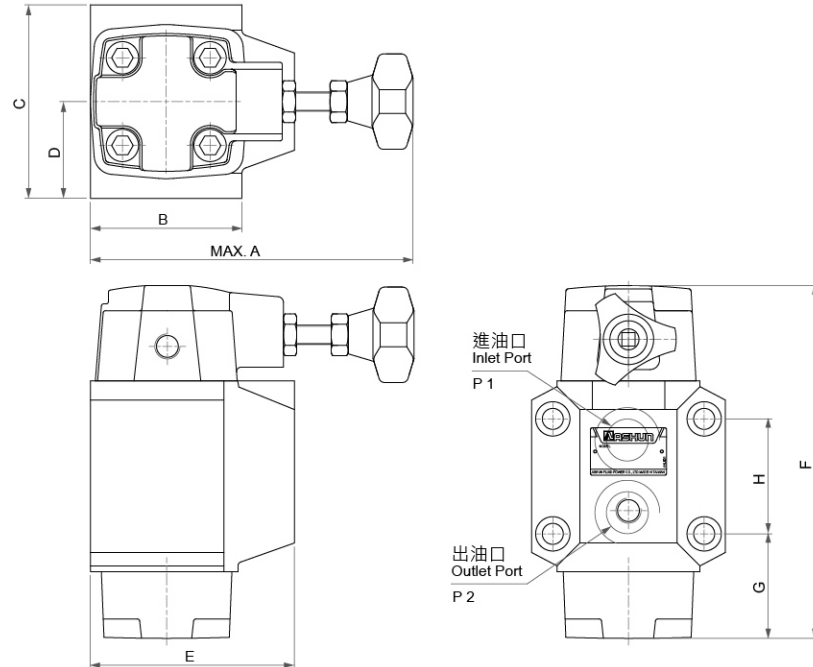

■ 尺寸說明 DIMENSION

型式 Model Series	A	B	C	D	E	F	G	H
BRCV-03G	164	59	89	44.5	90	155.5	49.6	42.8
BRCV-06G	164	70.5	102	51	108	188	50.7	60.3

● BRCV-10G

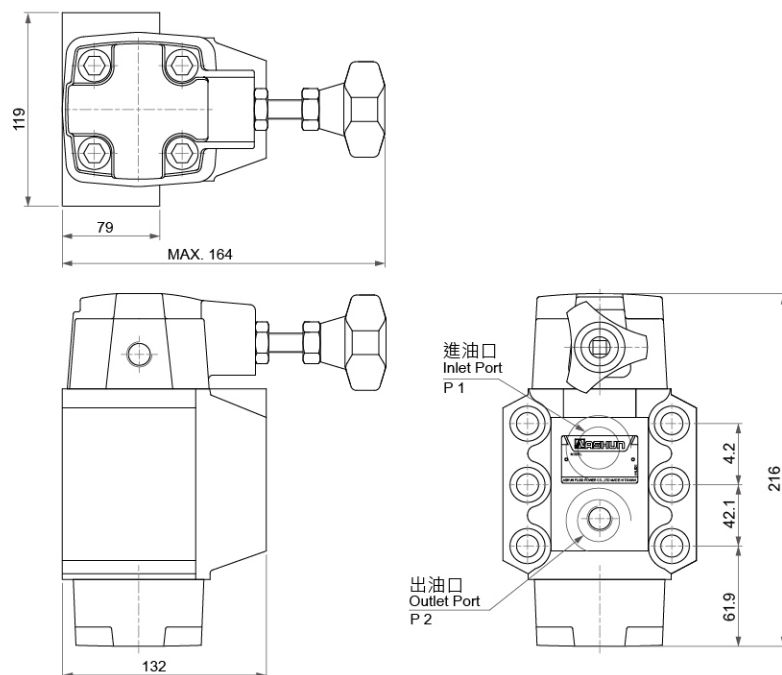

單向減壓閥 Pressure Reducing and Check Valves

● BRCV-03T

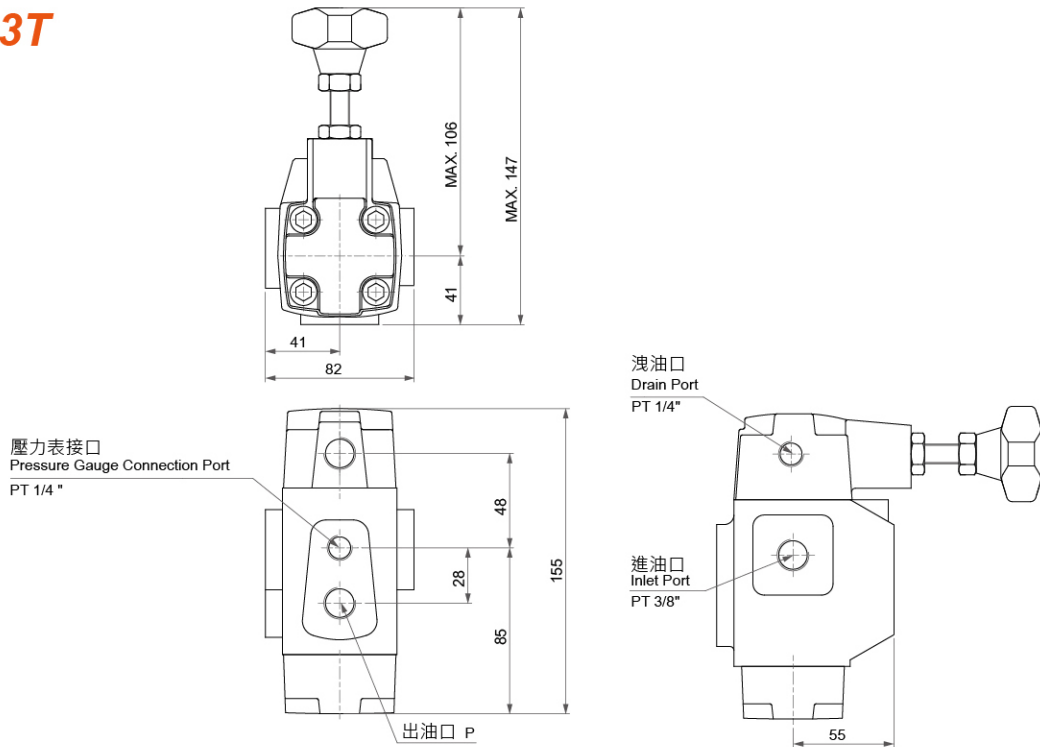

● BRCV-(06/10)T

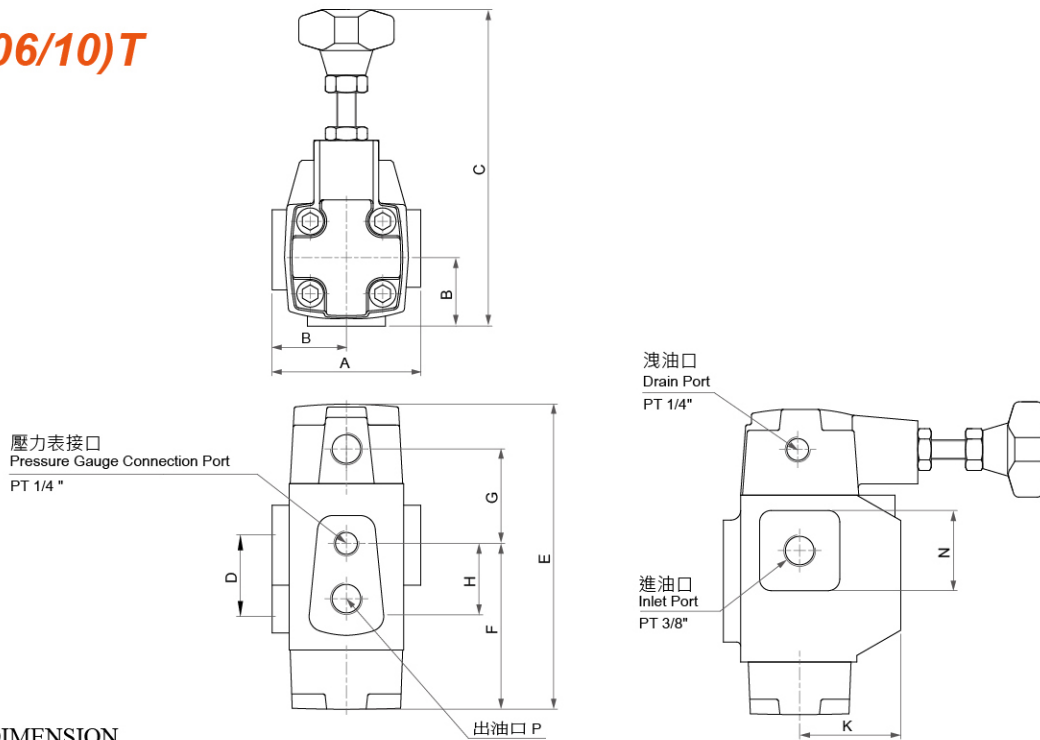

■ 尺寸說明 DIMENSION

型式 Model Series	A	B	C	D	E	F	G	H	K	N
BRCV-06T	94	48	150	42	179	97.5	44.5	42	66	62
BRCV-10T	137	68.7	167	52	216	124	52	52	84	79