

PT

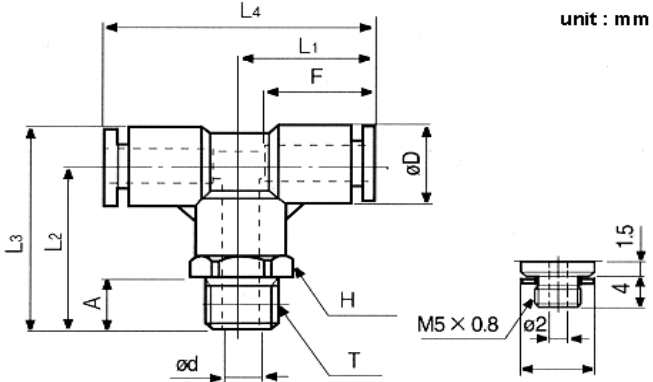

unit : mm



Fluid used	AIR (for compressed air only)	
Operating pressure	0 ~ 150 PSI	0~9.9Kg F/cm (0~990K Pa)
Negative pressure	-29.5 in Hg	-750mm Hg (10Torr)
Operating temperature range	32 ~140°F	0 ~60°C

ONE-TOUCH FITTING

- Fitting and tube can be easily connected and disconnected in one motion.

Tube Attachment

Disconnection - A secure connection is made by inserting the tube so that the ends touch, and detachment is completed by simply pressing the sleeve with your finger and pulling the tube, which takes only 1-2 seconds. No tools are required for connecting or detaching the tube.

PRESSURE RESISTANCE	10.5Kg f/cm ² (1050Kpa)
MAX.WORKING PRESSURE	7Kg f/cm ² (700Kpa)
MIN. WORKING PRESSURE	1Kg f/cm ² (100Kpa)
ADJUSTED TEMP & FLUID TEMP	5~60°C

PT	08	1/8
Model type	Hose size (φD)	Screw size

TUBE OUTRTER DIA

	Metric Size						Inch Size				
CODE	4	6	8	10	12	16	5/32	1/14	5/16	3/8	1/2
Tube outer diameter mm	φ4	φ6	φ8	φ10	φ12	φ16	φ5/32	φ1/14	φ5/16	φ3/8	φ1/2

Thread Type and Size

Metric Size					
CODE	M5	M6	M8	M10	M12
Tube outer diameter mm	M5*0.8	M6*1	M8*1	M10*1	M12*1.25

Taper Pipe Thread55				
CODE	01	02	03	04
Tube outer diameter mm	R1/8	R1/4	R3/8	R1/2

PT Product Code

MODEL(φ D-T)					
Tube(Metric)-R Thread(PT)			Tube(Inch)-Thread(NPT)		
PT 04-M5	PT 08-04	PT 16-04	PT 5/32-N01	PT 3/8-N01	
PT 04-01	PT 10-01	PT 04-M6	PT 5/32-N02	PT 3/8-N02	
PT 04-03	PT 10-02		PT 1/4-N01	PT 3/8-N03	
PT 06- M6	PT 10-03		PT 1/4-N02	PT 3/8-N04	
PT 06-01	PT 10-04		PT 1/4-N03	PT 1/2-N02	
PT 06-02	PT 12-02		PT 5/16-N01	PT 1/2-N03	
PT 06-03	PT 12-03		PT 5/16-N02	PT 1/2-N04	
PT 06-04	PT 12-04		PT 5/16-N03		
PT 08-01	PT 12-01		PT 5/16-N04		
PT 08-02	PT 06- M5		PT 5/32-UNF		
PT 08-03			PT 1/4- UNF		