

RLV Series

Roller Lever Mechanically Actuated Spool Valves

- 5/2, 3/2 - M5, 1/8, 1/4
- Excellent Durability
- Convenient Installation
- Direct Type, Quick Response

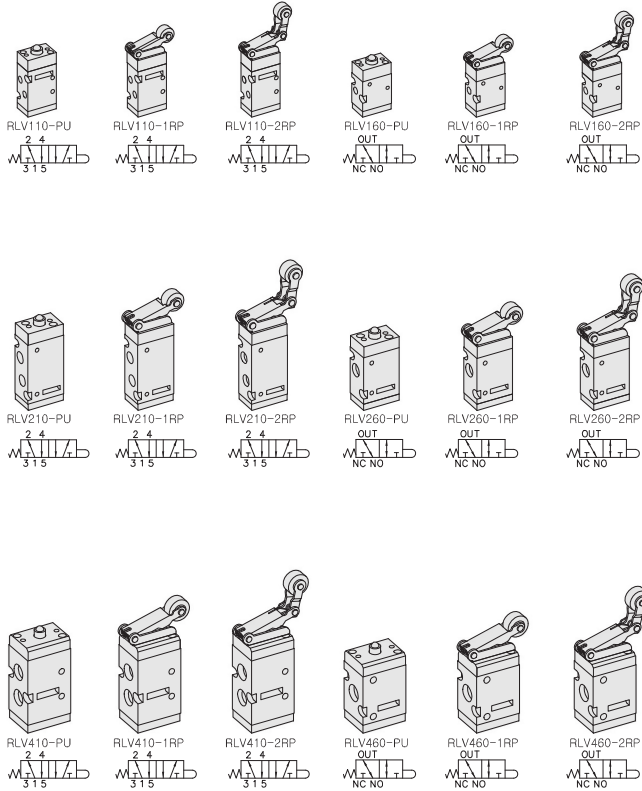

SPECIFICATION

ITEM	SERIES	RLV100	RLV200	RLV400
FUNCTION		5/2, 3/2-Way		
Fluids		Compressed Air & Inert Gases		
Port Size		M5	1/8	1/4
Pressure(bar)		0~8.0		
Eff. Sectional Area(mm ²)-5bar		3.5	12.6	19.0
Ambient & Fluid Temp.		5~60°C (41~140°F)		
Lubrication		Not Required(Use ISO VG32#)		

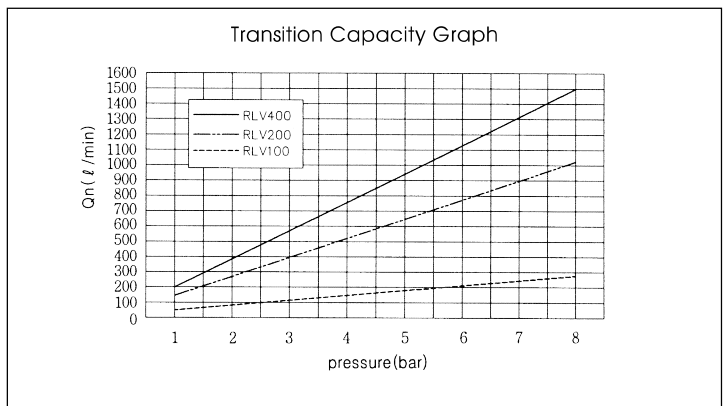

- ### The Material of Parts
- Valve Body : Die-Cast Aluminium
 - Lever Parts : Steel Plate, POM
 - Spool : Aluminium
 - Pilot Parts : Glass Filled Nylon
 - Seals : NBR
 - Cap : Zinc Pressure Die-Cast
 - Spring : Stainless
 - Button Parts : Stainless Steel

* The specification on each item can be amended without any prenotice to improve a performance.
 * The specification on each item can be different from actual specification.

ORDERING NO.

RLV1 1 0 - PU

Valve Series	Function	Port Size & Thread	Operator / Function
RLV1 : M5×0.8-Port Body	1 5/2 - Spring Return 6 3/2 - Spring Return	0 G 1 NPT	PU Pushrod 1RP Two-way Roller Plastic Lever 1RB Two-way Roller Bearing Lever 2RP One-way Roller Plastic Lever 2RB One-way Roller Bearing Lever
RLV2 : 1/8-Port Body			
RLV4 : 1/4-Port Body			

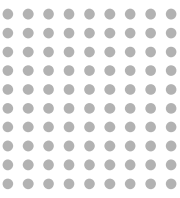

Roller Lever Mechanically Actuated Spool Valves

Port Thread M5, 1/8, 1/4

5/2-Way, Pushrod & Roller Lever Operation Thread-M5 × 0.8

	RLV110	RLV110-1RP	RLV110-2RP
T ₁	Valid Operation Dist	2.0mm	6.0mm 7.0mm
T ₂	InValid Operation Dist	1.0mm	2.0mm 2.0mm
F ₁	Pressure for Valid Operation	2.0kg	1.0kg 1.0kg
F ₂	Pressure for InValid Operation		

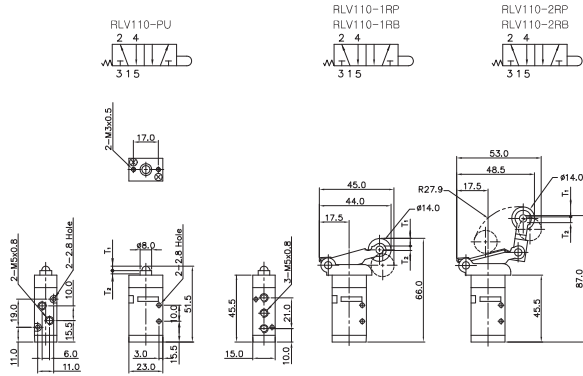

3/2-Way, Pushrod & Roller Lever Operation Thread-M5 × 0.8

	RLV160-PU	RLV160-1RP	RLV160-2RP
T ₁	Valid Operation Dist	2.0mm	6.0mm 7.0mm
T ₂	InValid Operation Dist	1.0mm	2.0mm 2.0mm
F ₁	Pressure for Valid Operation	2.0kg	1.0kg 1.0kg
F ₂	Pressure for InValid Operation		

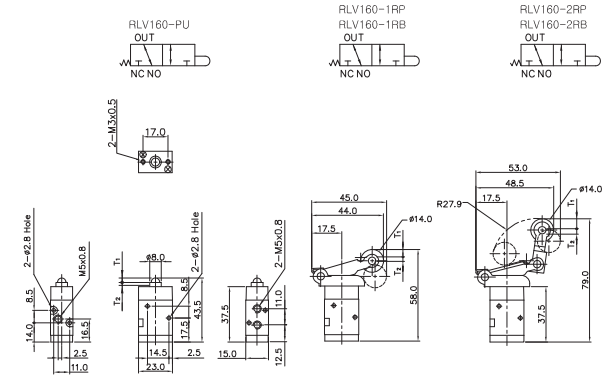

5/2-Way, Pushrod & Roller Lever Operation Thread-1/8

	RLV210	RLV210-1RP	RLV210-2RP
T ₁	Valid Operation Dist	3.0mm	8.5mm 9.5mm
T ₂	InValid Operation Dist	1.0mm	2.0mm 2.0mm
F ₁	Pressure for Valid Operation	2.5kg	1.5kg 1.5kg
F ₂	Pressure for InValid Operation		

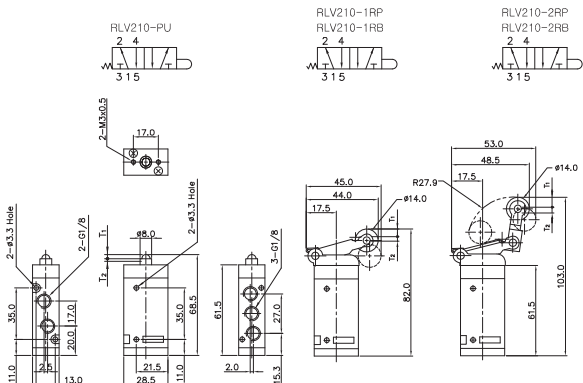

3/2-Way, Pushrod & Roller Lever Operation Thread-1/8

	RLV260-PU	RLV260-1RP	RLV260-2RP
T ₁	Valid Operation Dist	3.0mm	8.5mm 9.5mm
T ₂	InValid Operation Dist	1.0mm	2.0mm 2.0mm
F ₁	Pressure for Valid Operation	2.5kg	1.5kg 1.5kg
F ₂	Pressure for InValid Operation		

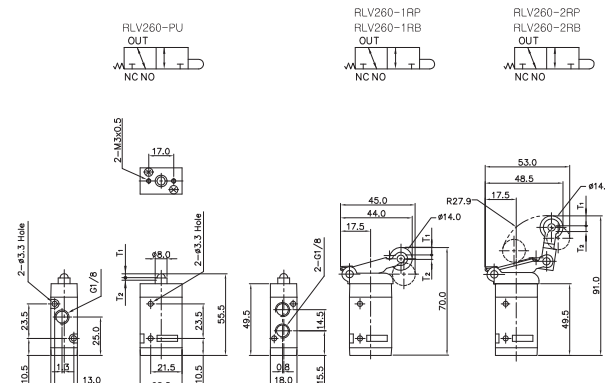

5/2-Way, Pushrod & Roller Lever Operation Thread-1/4

	RLV410	RLV410-1RP	RLV410-2RP
T ₁	Valid Operation Dist	3.6mm	9.0mm 10.5mm
T ₂	InValid Operation Dist	1.0mm	3.0mm 3.0mm
F ₁	Pressure for Valid Operation	3.5kg	1.5kg 1.5kg
F ₂	Pressure for InValid Operation		

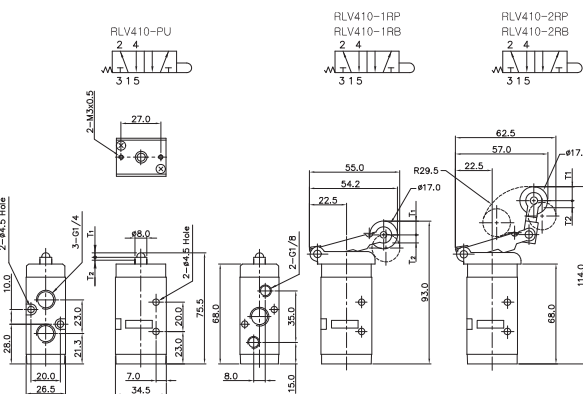

3/2-Way, Pushrod & Roller Lever Operation Thread-1/4

	RLV460-PU	RLV460-1RP	RLV460-2RP
T ₁	Valid Operation Dist	3.6mm	9.0mm 10.5mm
T ₂	InValid Operation Dist	1.0mm	3.0mm 3.0mm
F ₁	Pressure for Valid Operation	3.5kg	1.5kg 1.5kg
F ₂	Pressure for InValid Operation		

