

# SF2000. 1/8

"F" FLEXIBLE Series  
Solenoid / Pneumatic Valves

- 5/2, 5/3, 3/2 - 1/8
- 18mm Body Width
- Transition Flow 700ℓ/min (5bar)

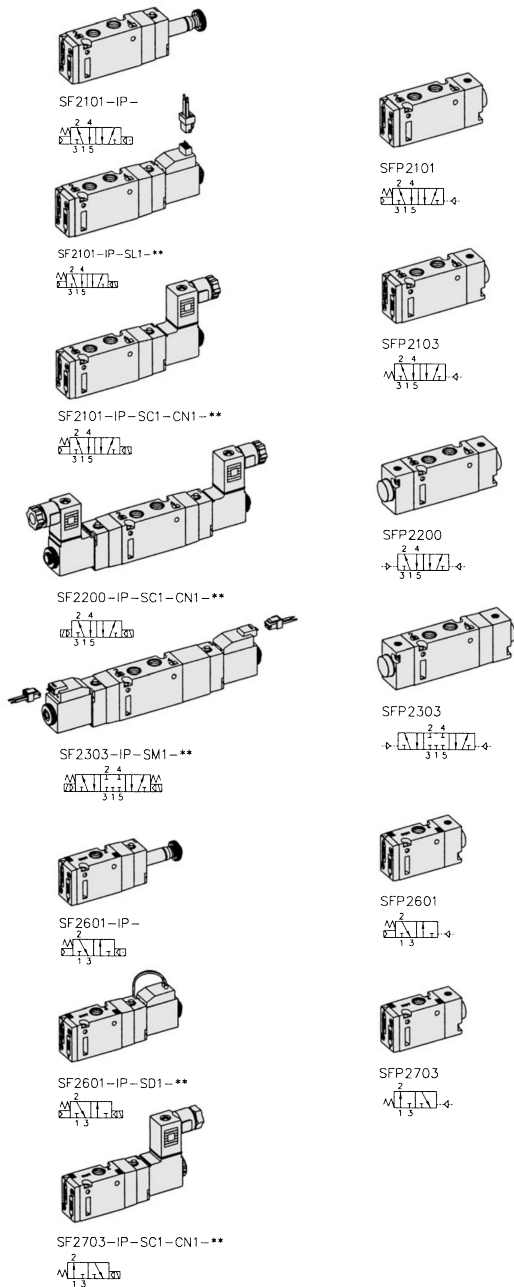

\*\* : Voltage Selection (see page 80)

## SPECIFICATION

ITEM	SERIES	SOLENOID, PNEUMATIC	
		FUNCTION	
		5, 3 Port 2 Position	5 Port 3 Position
Fluids		Compressed Air & Inert Gases	
Pressure(bar)		1.5~10.0	2.0~10.0
Eff. Section Area(mm <sup>2</sup> )-5bar		12.6	9.0
Ambient & Fluid Temp.		5~60°C (41~140°F)	
Response Time(5bar)		25ms or Less	35ms or Less
Max. Working Frequency		5c/sec	3c/sec
Lubrication		Not Required(Use ISO VG32#)	
Manual Override		Push Button(Standard), Lever Lock(Optional)	
Coil Insulation Class		F-Class or Equivalent	
Permissible Voltage Variation		±10% of Rated Voltage	
Off Min. Residual Voltage		AC:20% or Less / DC:10% or Less	
Power Consumption		Holding-AC:3.5VA(60Hz) / DC:2.5W	

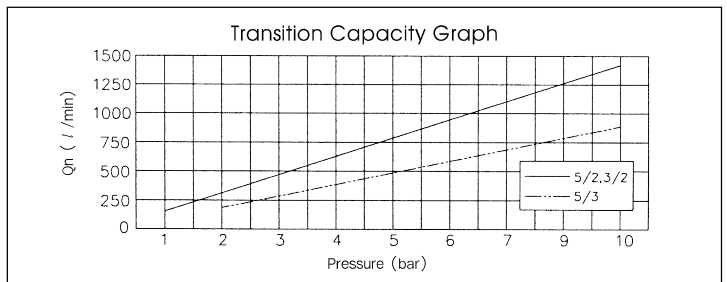

- ### The Material of Parts
- Valve Body : Die-Cast Aluminium
  - Spool : Aluminium
  - Seals : NBR
  - Spring : Stainless
  - Cap : Zinc Pressure Die-Cast
  - Pilot Parts : Glass Filled Nylon
  - Armature : Stainless Steel
  - Armature Seals : Viton

### Plug Connector With Clip

Ordering Code  
PG2-06 (L : 600mm)  
PG2-10 (L : 1,000mm)

\* The specification on each item can be amended without any prenotice to improve a performance.  
\* The specification on each item can be different from actual specification.

## ORDERING NO.

SF2 1 0 1 - I P - SC1 - CN1 - A2

Valve Series	Function	Part Size & Thread	Return Method	Int/Ext. Pilot	Manual Operator	Solenoid Coil Type	Connector Type	Voltage
SF2 : Solenoid Valve	1 5/2 Single	0 G 1/8	0 None	I Internal Pilot	0 None	0 None	0 None	0 None
	2 5/2 Double	1 NPT 1/8	1 Air + Spring		P Push Non-Locking	SC1 3 Pin Connector Coil	CN1 Normal Connector	A2 AC 220V
	3 5/3 Closed Center		2 Air		L Lever Locking	SG1 Grommet/Flying Leads	CD1 Connector With LED	A1 AC 110V
SFP2 : Pneumatic Valve	4 5/3 Open Center		3 Spring			SD1 Grommet/Flying Leads With LED	CZ1 Connector With LED & Surge Suppressor	A4 AC 24V
	5 5/3 Pressure Center					SL1 90 Degree Plug-in Wire Assembly With LED		D4 DC 24V
	6 3/2 Normally Closed					SM1 180 Degree Plug-in Wire Assembly With LED		D2 DC 12V
	7 3/2 Normally Open							

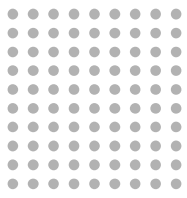

# Solenoid & Pilot Actuated Spool Valves

Port Thread 1/8

## 5Port 2Position Solenoid Valve

Single Solenoid  
SF2101-IP-SC1-CN1---

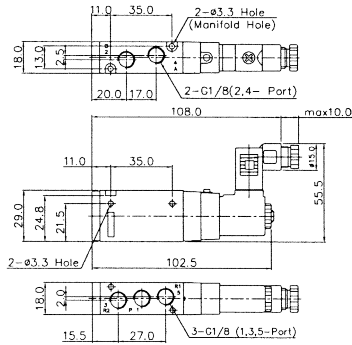

Double Solenoid  
SF2200-IP-SC1-CN1---

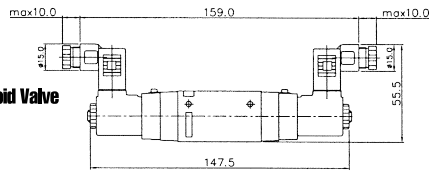

## 5Port 3Position Solenoid Valve

Closed Center  
SF2303-IP-SM1---



Exhaust Center  
SF2403-IP-SM1---



Pressure Center  
SF2503-IP-SM1---

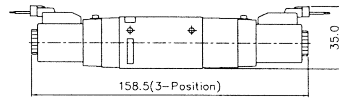

## 3Port 2Position Solenoid Valve

Normally Closed  
SF2601-IP-SD1---



Normally Open  
SF2701-IP-SD1---

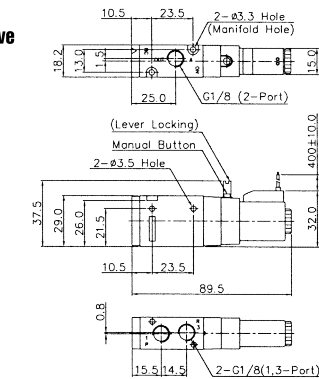

## 5Port 2Position Pneumatic Valve

Single Pneumatic  
SFP2101

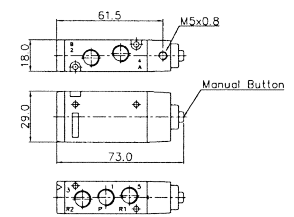

Double Pneumatic  
SFP2200

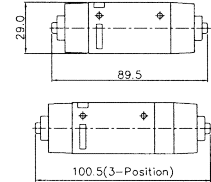

## 5Port 3Position Pneumatic Valve

Closed Center  
SFP2303

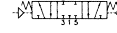

Exhaust Center  
SFP2403

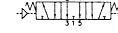

Pressure Center  
SFP2503

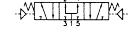

## 3Port 2Position Pneumatic Valve

Normally Closed  
SFP2601



Normally Open  
SFP2701

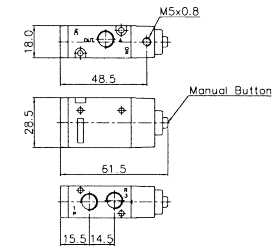

# MF2000 MANIFOLD BLOCK

(SF2000 Solenoid & Pneumatic Valve Use)

## 5-Port Manifold Block

MF2500-4

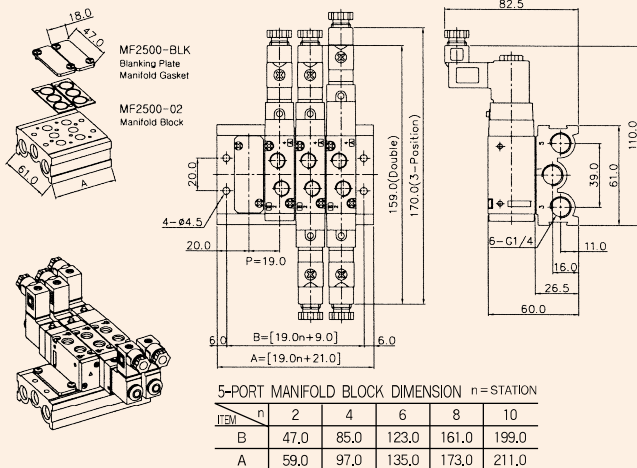

5-PORT MANIFOLD BLOCK DIMENSION n=STATION						
ITEM	n	2	4	6	8	10
B		47.0	85.0	123.0	161.0	199.0
A		59.0	97.0	135.0	173.0	211.0

## Manifold Block Ordering Code

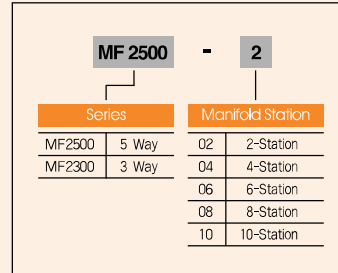

## Blanking Plate Ordering Code

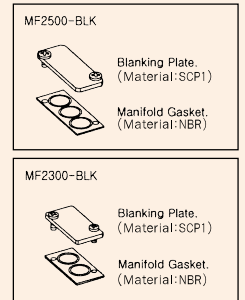

## 3-Port Manifold Block

MF2300-4

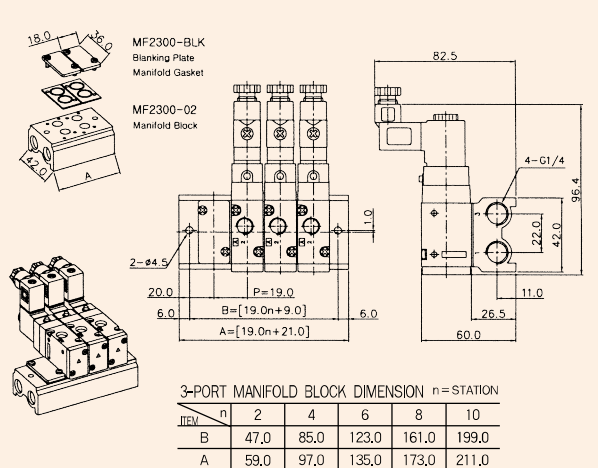

3-PORT MANIFOLD BLOCK DIMENSION n=STATION						
ITEM	n	2	4	6	8	10
B		47.0	85.0	123.0	161.0	199.0
A		59.0	97.0	135.0	173.0	211.0